



DEPARTMENT OF ENVIRONMENTAL SERVICES

Utilities and Environmental Policy Division

Water, Sewer and Streets Bureau, 4200 28th Street South, Arlington, VA 22206

TEL 703.228.6570 FAX 703.228.6585 www.arlingtonva.us

To: Property Owner **Date:** April 25, 2017
From: Water/Sewer/Streets Bureau
Subject: Driveway Apron Replacements

Construction and maintenance of driveway aprons on public streets is the responsibility of the property owner that uses the apron. Design and construction standards are regulated by the County to ensure that the public right of way is safely maintained, and so pedestrians can safely transverse the driveway apron along the sidewalk area. Aprons must be constructed in accordance with County standards.

General Policy

Construction of all aprons for new driveways, relocations, or modifications of an existing apron is the property owner's responsibility and the owner must obtain all appropriate right of way permits.

Arlington County, or its Contractors, will replace residential driveway aprons at a cost of \$750.00 for driveway aprons up to ten feet (10') wide as measured at the property line or back of apron. The cost for existing aprons wider than ten feet (10') will be \$75.00 per foot of width.

The replacement of a driveway apron may result in a decreased width at the curb level.

This work can be done as part of routine concrete maintenance or scheduled out of cycle within 6-8 weeks, weather and crew availability permitting.

This policy shall only pertain to replacement of existing aprons in the current location.

Unused driveway aprons will be removed at no cost upon request of the property owner.

As an alternative, the County will patch your apron or repair pedestrian tripping hazards on your apron with asphalt free of charge.

Please fill out the application attached to this packet and contact Nestor Sol at 703-228-6554 or nsol@arlingtonva.us to initiate the process to have your driveway apron replaced.

Examples of deteriorated aprons



New driveway aprons:



Reduced size driveway details are shown below and on the following page or full size versions are available upon request.

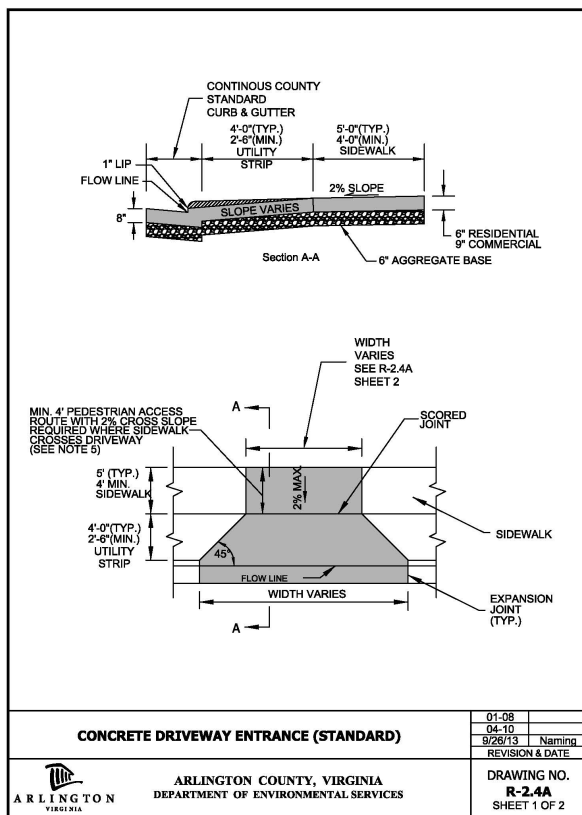

NOTES:

1. WHEN DRIVEWAY WIDTH EXCEEDS 16' A 3/4" MIN. DEPTH SCORED JOINT SHALL BE PLACED ON CENTERLINE OF DRIVEWAY ENTRANCE OR EVERY 10'.
2. CONCRETE DRIVEWAY ENTRANCE SHALL BE POURED MONOLITHICALLY.
3. FOR GRAVEL DRIVEWAY, 4' OF 4" THICK ASPHALT SHALL BE PLACED AT BACK OF THE CONCRETE APRON FOR THE WIDTH OF THE DRIVE.
4. PROVIDE 6" MINIMUM AGGREGATE BASE HAVING MINIMUM CBR-30 UNDER DRIVEWAY ENTRANCE.
5. OWNER SHALL DEDICATE ALL PERMANENT EASEMENTS NECESSARY TO PROVIDE ADA COMPLIANT DRIVEWAY ENTRANCE AND SIDEWALK IF EXISTING OR PROPOSED SIDEWALK INTERSECTS DRIVEWAY.

RESIDENTIAL AND MULTIFAMILY	DRIVEWAY WIDTHS	
	MINIMUM	MAXIMUM
SINGLE FAMILY - ONE ENTRANCE	N/A	17'
SINGLE FAMILY - TWO ENTRANCES	N/A	10'
MULTI FAMILY SMALL DEVELOPMENT	20'	30'
MULTI FAMILY LARGE DEVELOPMENT	20'	30'

COMMERCIAL	DRIVEWAY WIDTHS	
	MINIMUM	MAXIMUM
COMMERCIAL / MIXED USE / HIGHRISE & OTHER DRIVEWAY ENTRANCES USED AS ONE-WAY ENTRANCE	14'	20'
COMMERCIAL / MIXED USE / HIGHRISE & OTHER DRIVEWAY ENTRANCES USED AS A TWO WAY ENTRANCE	20'	30'
COMMERCIAL / MIXED USE / HIGHRISE & OTHER - FIRE LANE SEPARATE FROM DRIVEWAY ENTRANCES OR ONE-WAY ENTRANCES	20'	20'
LOADING DOCK	N/A	20'

CONCRETE DRIVEWAY ENTRANCE

04-10
9/28/13 Naming
REVISION & DATE

DRAWING NO.
R-2.4A
SHEET 2 OF 2

ARLINGTON COUNTY, VIRGINIA
DEPARTMENT OF ENVIRONMENTAL SERVICES

Application for Driveway Apron Replacement

Please fill out your name, address and telephone number below. A County representative will come out and measure the apron width in order to determine the cost. For all replacement driveway aprons, the County is required to comply with the American with Disabilities Act (ADA). This means that the style of your new apron may not match the style of your existing apron. **In addition, the County cannot guarantee that your vehicle will not scrape on the new apron. The property owner will be responsible for alterations to the driveway necessary to accommodate a lower profile apron.**

Name:

Cost:

Address:

Check #

Phone Number:

Email:

Signature:

Date:

Received by:

I understand that the replacement driveway apron is required to be constructed according to new standards and may not be similar in appearance to my existing apron. I understand that vehicles may scrape on the new apron and the risk of water overtopping a new lower profile apron will be increased. Arlington County warrants the new apron for 12 months from installation. Any defects in work shall be rectified at the discretion of the County.

Signature

Make checks payable to "Treasurer of Arlington County" and mail to:

Attn: Nestor Sol

Water, Sewer and Streets Bureau

4200 28th Street South

Arlington, VA 22206

Homeowner copy

Driveway Apron Replacement Policy

Page 4 of 5

April 25, 2017

Application for Driveway Apron Replacement

Please fill out your name, address and telephone number below. A County representative will come out and measure the apron width in order to determine the cost. For all replacement driveway aprons, the County is required to comply with the American with Disabilities Act (ADA). This means that the style of your new apron may not match the style of your existing apron. **In addition, the County cannot guarantee that your vehicle will not scrape on the new apron. The property owner will be responsible for alterations to the driveway necessary to accommodate a lower profile apron.**

Name:

Cost:

Address:

Check #

Phone Number:

Email:

Signature:

Date:

Received by:

I understand that the replacement driveway apron is required to be constructed according to new standards and may not be similar in appearance to my existing apron. I understand that vehicles may scrape on the new apron and the risk of water overtopping a new lower profile apron will be increased. Arlington County warrants the new apron for 12 months from installation. Any defects in work shall be rectified at the discretion of the County.

Signature

Make checks payable to "Treasurer of Arlington County" and mail to:

Attn: Nestor Sol

Water, Sewer and Streets Bureau

4200 28th Street South

Arlington, VA 22206

County copy